

Open-Area Smoke Imaging Detection (OSID) by Xtralis

White Paper

By Ron Knox
Xtralis Pty Ltd.



Background

A number of large-open spaces in the built environment present unique challenges to fire detection systems. Buildings such as stadiums, large atria, airports and rail stations, hotels and convention centers and warehouses demand a fire detection solution that is sensitive to diluted smoke but that is non-intrusive on the space.

A new approach known as Open-area Smoke Imaging Detection (OSID) has been invented and developed for use in normal/standard sensitivity applications.

OSID measures the extinction along a light beam caused by smoke particles along the direct path of the light beam, just like a traditional projected beam smoke detector, except that by using dual wavelengths and image processing many limitations are overcome and benefits added.

To understand the operation of the new system we must first look at how existing projected beam products work, and at their benefits and limitations.

OSID
by  **xtralis™**

Principle of Operation of Traditional Projected Beam Detectors

The projected beam smoke detector is arguably the easiest to understand of all the smoke sensors available, since it relates well to the simple human observation that a light gets dimmer when smoke obscures the view. Inherently, measuring light attenuation (aka extinction, or obscuration) cannot reach the level of stability and hence sensitivity of a light scattering detector, particularly over short distances. Hence beam detectors are not generally considered as capable of very early warning performance as are light scattering instruments. Put simply, this is because a scattering detector is measuring a large increase in a near-zero signal whereas an extinction detector needs to resolve a small decrease in a big signal.

This gives an inherently lower stability, higher noise reading. Nonetheless, beam detectors when applied correctly can be surprisingly effective in many circumstances and can surpass spot-detector performance. But they do have some fundamental issues that have often caused them to be a “grudge buy” and to be considered as a low-end, cost-driven choice, suitable only when nothing else can be made to fit.

A classical beam detector uses two units, called a transmitter and a receiver. Inside the transmitter a light source (typically an infra-red LED) flashes periodically. Light from the LED is focused into a tight beam by a lens, and a finely adjustable mechanism is provided to allow the beam to be directed from where the transmitter is mounted at one end of a room towards the receiver or reflector(s) at the other end, which could be 100 m/330 ft away. The receiver also has an alignment mechanism and a lens which focuses the beam onto a light sensor, typically a silicon photodiode. In highly simplified form the key optical elements are represented in this diagram.

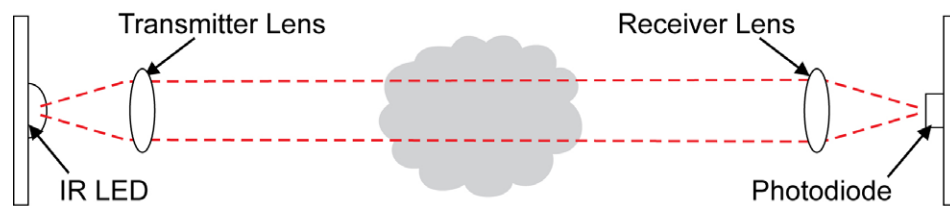

Figure 1 - Key Optical Elements

The electrical output from this photodiode is amplified and measured so that the signal reduction due to smoke present between the transmitter and receiver can be determined. In alternative designs the transmitter and the receiver are housed together in a single enclosure, and are aligned onto a remote reflector. The reflector is not a flat mirror (as this would need to be exactly aligned) but is made up of corner reflector elements which reflect the light strongly back towards the source.

Problems with Traditional Beam Detectors

The perceived issues with traditional beam detectors are primarily difficulty in alignment and proneness to false alarms. Such false alarms may be triggered by, for example, objects such as banners, balloons or even birds entering the beam path, dust in the air or insects such as moths crawling on the optical surfaces of the transmitter, receiver or reflector. Normal building movement caused by temperature changes etc will also affect alignment.

Typical beam detectors require the initial alignment to be accurate to about 0.1 degrees of movement; tricky but achievable. Some designs of detector use software-controlled motor driven mechanisms to adjust the fine alignment automatically to obtain and subsequently maintain the strongest signal available.

OSID Principle of Operation

The improvements that OSID offers against traditional beam detectors stem from three core design ideas:

- Two wavelengths of light are used:
 - Use of ultra-violet (UV) and infra-red (IR) wavelengths outside the human visible range assists the identification of real smoke compared to larger objects such as fork-lift trucks, insects and dust; thus reducing opportunities for false alarms.
- A CMOS imaging chip with many pixels (just as used in a digital camera) is used rather than a single photo-diode, providing:
 - Multiple source capability (i.e. several beams into a single receiver)
 - Automatic alignment and movement tracking by software only
 - Location of the smoke in a large space
- A unique method for aligning:
 - “Ball and socket” housing which allows a wide range of horizontal and vertical movement
 - “Laser screwdriver” for simple and fast alignment

Application and Benefits

Simple Linear Configuration

In its simplest configuration, a system consists of one Emitter and one Imager placed on opposite walls, and roughly aligned with one another.

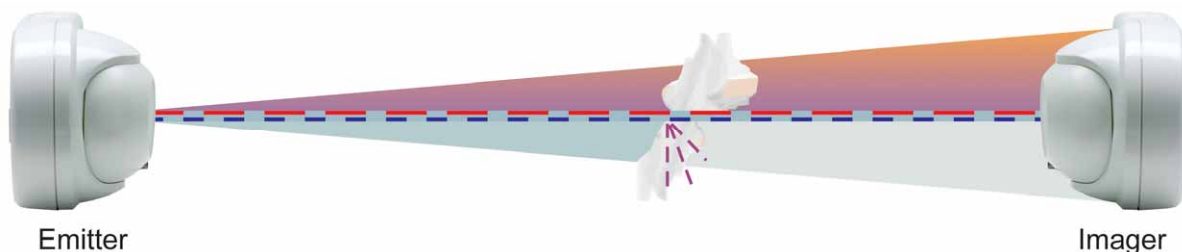

Figure 2 – Linear OSID Layout

Again, this is a simplified diagram for clarity; in reality the beams from the Emitters are conical with a width of $\pm 5^\circ$. Roughly pre-aligning the Emitter to 0.5° is easy using an alignment tool described in more detail later. For a single beam path, an Imager fitted with a “telescopic” lens giving $\pm 5^\circ$ field-of-view is used and this too can be easily pre-aligned with the same tool. With 10° total field of view lens the maximum range for the system is ~ 150 m (500 feet). Note that the field of view angle given is for the horizontal plane; since the Imager chip has a conventional 14:9 aspect ratio the vertical axis is reduced accordingly.

One significant benefit is that, rather than having to mechanically align the optical system with great precision, the exact location of the Emitter in the Imager’s field of view is determined automatically by the Imager software. This software identifies the location of the image of the Emitter which may be anywhere on the active surface of the Imager chip. To visualize this, one might simply think of the active part of the imaging chip as creating the picture that would be seen on a normal TV or computer monitor screen. In a single frame taken when the transmitter is blinking on, it appears as a bright spot in the picture. Any future re-positioning of the image caused by building movement is also tracked by the software, eliminating false alarms due to movement without needing any motorized mechanical parts.

Resistance to False Alarms

If any smoke enters the beam the small particles in the smoke will reduce the UV light transmission more significantly than the IR light transmission, whereas dust & objects affect both equally. Software can examine the strengths of these signals, and how they change over time, and make a determination of whether to raise an alarm or to flag a trouble condition. This appropriate use of UV as well as IR light both reduces the probability of a false alarm and enhances the sensitivity to small particle smokes, which has often been relatively low on optical detectors.

Additionally, clear materials loaded with dyes which absorb UV and IR to differing extents can be used as a convenient "smokeless" test sheet for commissioning and maintenance tests in the field. Conventional beam detector filters obscure both wavelengths and are simply reported as a trouble condition, not as a fire.

Multiple Emitters for Area Protection

For protecting a room, up to 7 Emitters can be deployed around the walls.

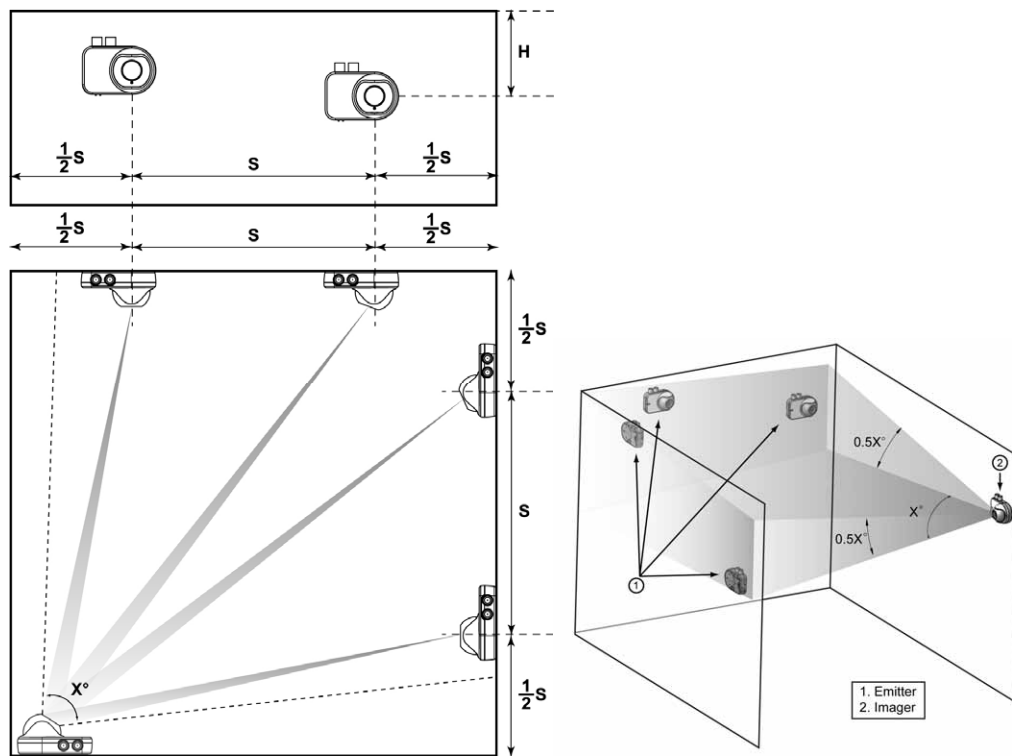

Figure 3 - Multi-Emitter Area OSID Layout

In this case an 80° lens (+/- 40° field of view horizontally) can be fitted to the Imager. With 80° field of view lens the maximum range for the system is 34m (110 feet).

Alternative lens options include a 38° field of view giving a range of 60 m (197 ft).

An important target of the design is that the overall power consumption of the emitter is very low, enabling it to run for many years on an internal battery (although a wired version is to be made available for those who wish it). By using a Lithium battery, up to 5 years of life can be anticipated. This reduces installed cost by removing the need for cabling to the Emitters. Installation of multi-beam applications needs wiring only between the Imager and a fire panel.

Range can be further increased by increasing the Emitter power. High powered emitters roughly double the range of the 80° and 38° units.

Technology Details

Pre-alignment

To operate correctly it is only necessary that the Imager and Emitters are very roughly pre-aligned by hand to ensure that all Emitters are comfortably contained within the field of view, and that the Imager falls within the wide beams of the Emitters.

This could be achieved in many ways, but the design choice for the current product design is to mount both the Emitter and the Imager optical assemblies inside a “ball and socket” housing which allows a range of movement of $\pm 60^\circ$ in the horizontal and $\pm 15^\circ$ in the vertical. These may be swapped around if needed, e.g. to look down a staircase, by simply mounting the housing on the wall in a 90° rotated orientation.

The ball housing is supplied free to move, but can be rigidly locked into place using a tool with a hex-key end. This tool engages with a steel-lined aperture at the front of the ball which is precisely aligned to the optical centre of the Imager or Emitter. The tool is equipped with a pre-aligned laser pointer, the design of which is similar to devices used to pre-set telescopic rifle sights. The installation procedure is simply to position the laser spot as required (details below) and to rotate the tool by one quarter-turn to both lock the ball in place, and in the case of the Emitter, to switch it on. A reed switch activated by a magnet on the locking mechanism switches on the Emitter only when mounted and locked. This prevents the battery discharging during shipping and storage, and also confirms that the unit has been aligned and locked in place. This alignment and fastening tool has been dubbed a “laser screwdriver”.

When the system is using a single Emitter at a long range the field of view of the lens may be 10° width in total; i.e. ± 5 degrees. Preferably, the Emitter image appears in roughly the middle of the picture. Achieving 0.5 degrees is easy (this represents a target about 1 foot across 60 feet away) in fact, people find it harder to resist spending unnecessary time by getting the spot exactly onto the 2 inch window.

When a 80° and/or 38° field of view lens is used with multiple Emitters distributed around a room, perhaps at different heights, the laser is directed onto the estimated mid-point of the Emitters.

Emitter Operation

The OSID Emitter contains a number of key elements, illustrated in this diagram.

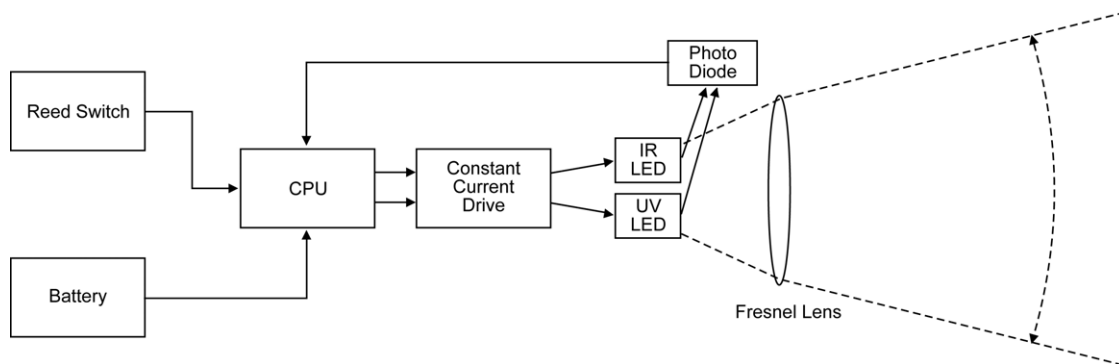

Figure 4 - Emitter Unit Physical Architecture

Light from the two (or more) LEDs is focused into a projected beam by a Fresnel lens/diffuser into a diverging beam of about $\pm 5^\circ$ width. It is desirable that the LED chips are physically close together to minimize divergence between the UV and IR beam patterns and to prevent small objects like insects from blocking one wavelength more than the other, and so the LED dies are mounted side-by-side within a custom made package.

A low power micro-controller delivers a carefully defined sequence of pulses to the LEDs, which is unique to each Emitter made, as is expanded on below.

The intensity of each pulse is measured by the photodiode and the CPU's internal A/D converter. This measurement is used to provide compensation for LED temperature and ageing effects. Varying the drive pulse compensates the intensity as required. The effects of battery voltage and LED forward voltage variations are eliminated by the use of a constant current drive circuit.

Imager Operation

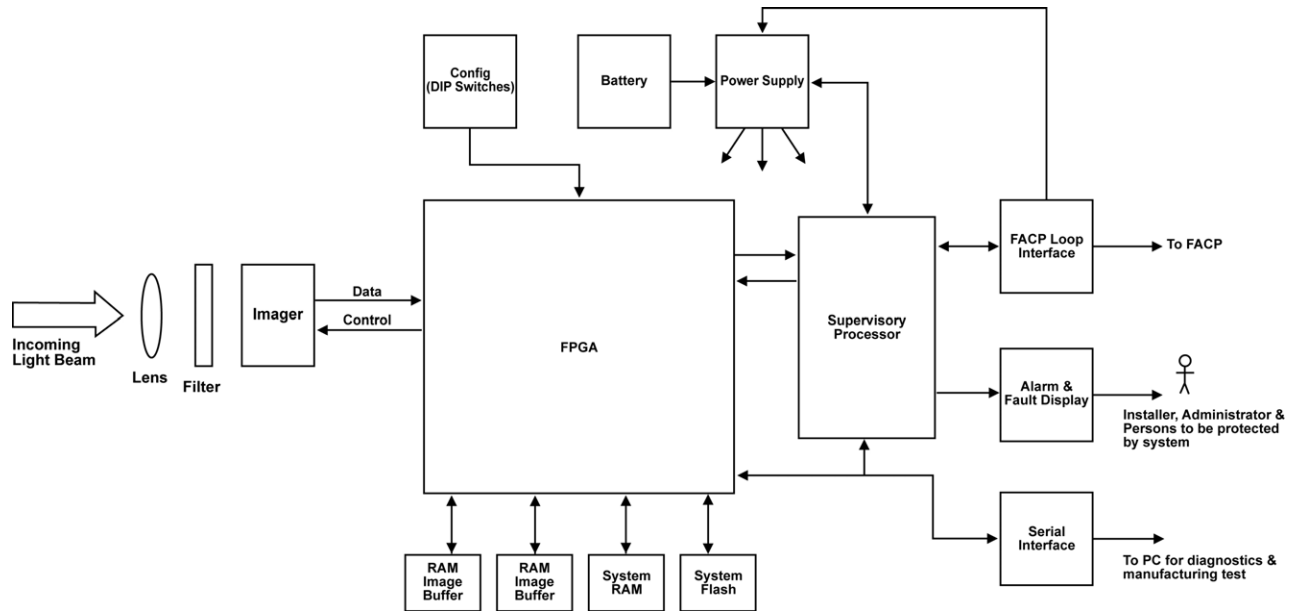

Figure 5 - Imaging Unit Physical Architecture

With the exception of the field wiring termination card, the OSID Imager optics and electronics are fully housed within a ball that can be moved to pre-align the device. A flat flex cable links the electronics to the termination card. The optics is internally sealed in a moisture proof tube, equipped with an optional heater to prevent condensation forming on the outer surface in humid / cold condensing environments.

The Imager is fitted with a CCTV type lens that has been selected for minimum dispersion for UV and IR wavelengths (i.e. the focal length of the lens for both wavelengths are nearly identical) and for good temperature response characteristics.

The Imager is also fitted with a dyed glass filter, designed to be almost opaque to all but the 2 wavelengths of interest. This contributes to the system's ability to work in a wide range of lighting conditions, including a full sunlit scene, and in strong artificial lighting including flickering sources like mercury vapor lamps or arc-welding.

However, most of the sensitivity and tolerance to bright lighting comes from the technique of "background subtraction". This uses the very fast capture speed of the imaging chip to measure the light level around the Emitter image immediately before and after the wanted flashes, and then subtracts them so that the uncorrelated background contribution disappears entirely.

Challenges in the Technology Development

Using a video imaging chip rather than a simple photo-diode provides benefits for a beam detector, but in practice these techniques are challenging to apply. The smaller particles that are generated in most fires at an early stage, and by all fires once they transition to the increased threat stage of flaming, interact more strongly with short wavelength light (UV of ~400 nm) than they do with long wavelength light (IR of ~850 nm). This is a consequence of the Mie theory of light scattering. Incidentally, this scattering theory is still applicable to an extinction measuring device, since much of the light beam is not actually absorbed by the smoke so much as scattered away from the receiver. Having said that, black smokes do absorb a larger proportion of the light, which is exactly why they look black, and is also why light-scattering detectors and light-extinction detectors cannot be calibrated to give the same readings for both white smoke and black smoke.

Conceptually, a monochrome video imaging chip is just a grid of many light sensitive elements, each one acting like a photodiode to form a single pixel in a picture. It also contains circuitry and micro-code to capture individual picture frames and to transfer each pixel output to memory for processing. After being converted to a digital value, the signal from each pixel is expressed in “grey levels” going from black to full brightness. Ideally, each pixel should range from 0 grey levels, meaning complete darkness, up to about a typical maximum of about 1000, meaning full measurable intensity. Above this the pixel is said to be saturated; which is to be avoided since any stronger light level cannot be measured.

When the unit is first started up the software has no knowledge of exactly where in the picture frame any Emitters might appear; so it begins a search. The CMOS video imaging chip used has a few hundreds of thousands of pixels to search, and each Emitter flashes for less than 1/1,000th of the time, so finding an Emitter (and there may be up to 7 in the view) is challenging. This is made more difficult by the fact that there may well be many other bright and varying light sources in the picture.

The system can first identify candidate light sources that might be Emitters and then examine them closely to determine if they have the right timing characteristics to be definitely identified as the wanted sources.

While in principle the Imager can see all Emitters at once, in practice it can only capture a partial frame quickly, and so any timing collisions must be brief events that preferably cause only one or two flashes to be skipped and so do not impact system performance. To achieve this every single Emitter has a unique code identifier which is communicated to the Imager via a data pulse attached to each flash sequence which is used to “jitter” the flash sequence timing in a unique but predictable way so that no two units will ever stay in lock-step.

Conclusion

In fire detection the most important trade-off is the reliable detection of actual fire threats while minimizing the cost, disruption and perhaps most importantly the loss of credibility caused by false alarms. The industry strives to improve methods to reliably and economically identify false stimuli such as dust, steam and macroscopic objects while ensuring a safe response to real threats. Dual wavelength measurement alone is not a complete panacea, but used intelligently and in combination with both a careful signal analysis approach and an imaging-based automatic alignment scheme it can substantially improve a fundamentally promising technology that has developed a negative reputation.

Biographical Sketch

Ron Knox, B.Sc. Hons. Graduating in Control Engineering from The University of Sussex in England, Ron has worked in a broad range of Engineering disciplines including Electronics, Software, Mechanical and Systems Engineering in military and commercial applications ranging from weapons guidance to computer security. For many years Ron has worked in the Fire industry, the last 17 being in his adopted home of Australia. Xtralis are the manufacturers of VESDA and Ron led the development of their flagship product LaserPLUS which has since become the world's most successful aspirated early warning smoke detector. He leads the New Technology Group in Xtralis, and now introduces the latest innovation: **OSID**.

www.xtralis.com

The Americas +1 781 740 2223 **Asia** +852 2916 8894 **Australia and New Zealand** +61 3 9936 7000

Continental Europe +32 56 24 19 51 **UK and the Middle East** +44 1442 242 330

The contents of this document is provided on an "as is" basis. No representation or warranty (either express or implied) is made as to the completeness, accuracy or reliability of the contents of this document. The manufacturer reserves the right to change designs or specifications without obligation and without further notice. Except as otherwise provided, all warranties, express or implied, including without limitation any implied warranties of merchantability and fitness for a particular purpose are expressly excluded.

This document includes registered and unregistered trademarks. All trademarks displayed are the trademarks of their respective owners. Your use of this document does not constitute or create a licence or any other right to use the name and/or trademark and/or label.

This document is subject to copyright owned by Xtralis AG ("Xtralis"). You agree not to copy, communicate to the public, adapt, distribute, transfer, sell, modify or publish any contents of this document without the express prior written consent of Xtralis.

