



IR160W6-10, IR160W6-20

Wireless passive infrared detector

for Sintony 60 (IC60) SiWay Protocol

- **18 m wide-angle with look down zone or 30 m continuous curtain (optional)**
- **Low power design – battery will last for 4 years**
- **Automatic temperature compensation**
- **Optimum white light filter through patented black triplex mirror optics**

Versatile application. The design is visually attractive but discreet, making the IR160W6 the ideal motion detector for industrial and commercial applications, as well as for more demanding and sophisticated applications in the private sector.

Fast and easy installation. The versatile housing allows wall and corner installation without accessories.

Outstanding immunity. A comprehensive protection concept makes the detector insensitive to environmental problems.

Safe detection. A look down zone for crawl protection and uniform sensitivity in the 'chessboard' zone pattern guarantee a high level of detection reliability. The multi-criteria signal analysis system differentiates intelligently and reliably between intruders and disturbance signals. A periodical transmission signal every 7 min indicates presence.

Coverage areas and dimensions

Wide angle mirror (standard)

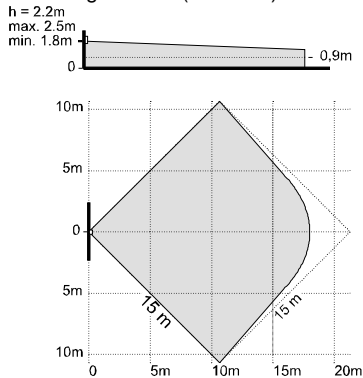

Curtain mirror IRS272 (option)

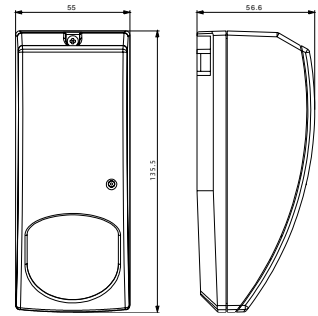
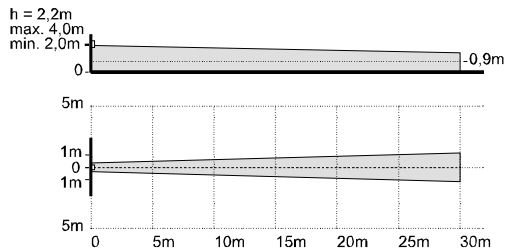

Technical data

Coverage area – Wide angle / Curtain IRS272	18 m / 30 m
Wireless module – Range / Frequency	up to 300 m at open space/ 868 MHz, 915 MHz
Lithium battery (1 x 3.6 V) – Life time	approx. 4 years
Identification	Unique ID serial number-24 bit
Event Transmission	Alarm, Tamper, Test, Supervision, Low Bat (30 Days in advance)
Data Protocol	SiWay- Sintony 60
Test mode / activation	Walk test & Alarm transmission test by tamper contact or magnet
Walk test auto reset	1 minute after activation
Power Savings	Automatic Power Saver
EMI rejection, 0 ... 2 GHz	> 20 V/m
Battery	Lithium 3 V Type: xx123 Size: 2/3 AA
Environmental conditions	
– Operation temperature	-10 ... +50° C
– Storage temperature	-20 ... +60° C
– Humidity (EN60721)	< 95 % r.h., non condensing
– Housing protection (EN60529, EN50102)	IP41 / IK02
Complies with: EN 50130-4, EN301489, EN300220, EN50081, EN60950 (ITE), EN50131-1, EN 50131-5-3, TS50131-2-2, Security Grade 2, Environmental Class II, TO14A:2006, EMC 89/336EEC, SAFETY 73/23/EEC	

Ordering data

Type	Part no.	Designation	Weight
IR160W6-10	A5Q00013963	Wireless passive infrared detector incl. Battery 868 MHz	0.120 kg
IR160W6-20		Wireless passive infrared detector incl. Battery 915 MHz US	0.120 kg
IRS272	571733	Curtain mirror (set of 4 pcs) Lithium 3V Type: xx123 Size: 2/3AA	0.050 kg 0.020 kg
IRUM20	562247	Wall mounting bracket	0.030 kg
IRUM30	562250	Ceiling mounting bracket	0.075 kg

Siemens Switzerland Ltd
International Headquarters
Gubelstrasse 22
CH – 6301 Zug
Tel. +41 41 724 24 24
Fax +41 41 724 35 22
www.sbt.siemens.com

© 2012 Copyright by
Siemens Building Technologies AG
Data and design subject to change without notice. Supply subject to
availability.